



2R-III

THE STRONG, THE PROUD



- 20 yd³ to 32 yd³ body sizes
- Up to 1000 lbs/yd³ compaction
- Largest hopper sweep in the industry with 5.5" bore packer/carrier cylinders
- Low load sill height of 4-5/8" below frame
- Single piece body walls for increased strength and seamless appearance
- Residential, Commercial, and Demolition packages available
- Hopper shape minimizes pre-compaction, reducing wear and maximizing payload
- Packer and Carrier Slide Shoes with Chromium overlay extend service life and reduce maintenance points
- Fully Integrated Labrie CNG System – roof, frame and back of cab mount – 50 to 100 DGE available

Body Specs	2R-III HD Residential	2R-III HD Demolition	2R-III HD Commercial
Body Trough Floor	5/16" 50W 50,000psi	5/16" 50W 50,000psi	5/16" 50W 50,000psi
Body Sides	10ga A1011 80,000psi	10ga A1011 80,000psi	10ga A1011 80,000psi
Body Roof	10ga A1011 80,000psi	10ga A1011 80,000psi	10ga A1011 80,000psi
Body Ramp Liners	-	1/4" A715 GR80 80,000psi (AR 450, 175,000 psi optional)	1/4" A715 GR80 80,000psi (AR 450, 175,000 psi optional)
Body Roof Liner (Body Rear End)	-	-	10ga A1011 80,000psi
Body Sides Liners (Body Rear End)	-	-	10ga A1011 80,000psi
Ejector Specs	2R-III HD Residential	2R-III HD Demolition	2R-III HD Commercial
Ejector Panel Face Plate	3/16" 50W 50,000psi	3/16" 50W 50,000psi	3/16" 50W 50,000psi
Packer-Carrier Specs	2R-III HD Residential	2R-III HD Demolition	2R-III HD Commercial
Compaction ratio (lbs/yd ³)	1000	1000	1000
Packer Panel Face Plate	1/4" A656 GR80 80,000psi	1/4" A656 GR80 80,000psi	1/4" A656 GR80 80,000psi, liner 1/4" 50W 50,000psi
Carrier Panel Face Plate	3/16" 50W 50,000psi	3/16" 50W 50,000psi	3/16" 50W 50,000psi, liner 3/16" 50W 50,000psi
Hydraulic Specs	2R-III HD Residential	2R-III HD Demolition	2R-III HD Commercial
Pump	Gear	Gear	Gear
Pump Capacity	42 gpm @ 1200 rpm	42 gpm @ 1200 rpm	42 gpm @ 1200 rpm
Max. Operating Pressure	2,300 psi	2,300 psi	2,300 psi
Oil Reservoir	50 gal	50 gal	50 gal

Note: Specifications subject to change without notice

Hopper Specs	2R-III HD Residential	2R-III HD Demolition	2R-III HD Commercial
Hopper Size (yd ³)	3.5	3.5	3.5
Hopper Opening Width	80"	80"	80"
Hopper Opening Height	57"	57"	57"
Hopper Depth	18"	18"	18"
Loading Sill Below Chassis Frame	4-5/8"	4-5/8"	4-5/8"
Hopper Floor	1/4" 100QT 100,000psi (AR 450, 175,000 psi optional)	1/2" 100QT 100,000psi (AR 450, 175,000 psi optional)	1/2" 100QT 100,000psi, front liner 1/4" A514 100,000psi
Hopper Sides (upper)	1/4" 50W 50,000psi (AR 450, 175,000 psi optional)	1/4" 50W 50,000psi (AR 450, 175,000 psi optional)	1/4" 50W 50,000psi
Hopper Sides (lower)	1/4" 50W 50,000psi (AR 450, 175,000 psi optional)	1/4" 50W 50,000psi (AR 450, 175,000 psi optional)	1/2" 50W 50,000psi
Cylinder Specs	2R-III HD Residential	2R-III HD Demolition	2R-III HD Commercial
Ejector Cylinder (20yd ³ bodies)	3 stages 6-1/2" bore x 94-3/16" stroke	3 stages 6-1/2" bore x 94-3/16" stroke	-
Ejector Cylinder (25yd ³ bodies)	3 stages 6-1/2" bore x 115-9/16" stroke	3 stages 6-1/2" bore x 115-9/16" stroke	3 stages 6-1/2" bore x 115-9/16" stroke
Ejector Cylinder (29yd ³ bodies)	4 stages 6-1/2" bore x 148-1/4" stroke	4 stages 6-1/2" bore x 148-1/4" stroke	4 stages 6-1/2" bore x 148-1/4" stroke
Ejector Cylinder (32yd ³ bodies)	5 stages 7-1/2" bore x 170-5/16" stroke	5 stages 7-1/2" bore x 170-5/16" stroke	5 stages 7-1/2" bore x 170-5/16" stroke
Packer Cylinders	5-1/2" bore x 4-1/2" rod x 30-5/16" stroke	5-1/2" bore x 4-1/2" rod x 30-5/16" stroke	5-1/2" bore x 4-1/2" rod x 30-5/16" stroke
Carrier Cylinders	5-1/2" bore x 4-1/2" rod x 30-5/16" stroke	5-1/2" bore x 4-1/2" rod x 30-5/16" stroke	5-1/2" bore x 4-1/2" rod x 30-5/16" stroke
Tailgate Cylinders	4" bore x 3-1/2" rod x 32-11/16" stroke	4" bore x 3-1/2" rod x 32-11/16" stroke	4" bore x 3-1/2" rod x 32-11/16" stroke



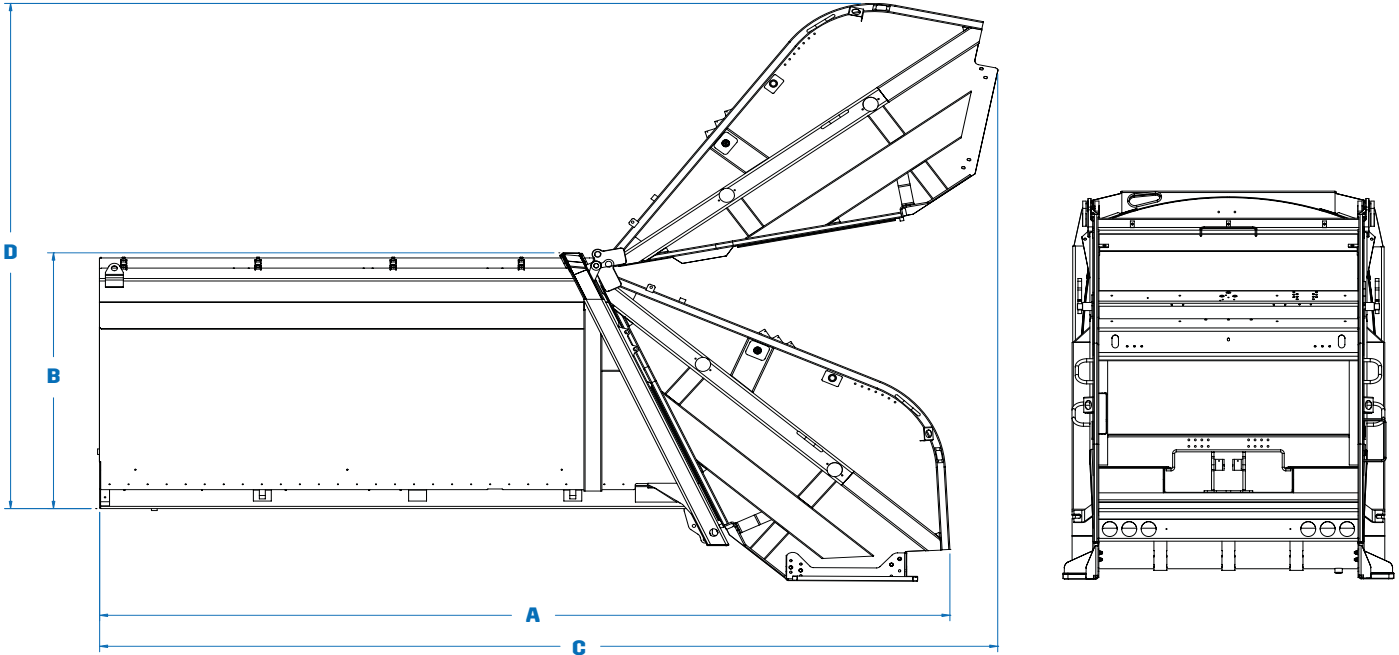

Body Dimensions	20yd ³	25yd ³	29yd ³	32yd ³
A. Overall Length, Tailgate Closed (in.)	263	285	318	341
Overall Width (in.)	102	102	102	102
B. Overall Height Above Frame, Tailgate Closed (in.)	93	93	93	93
C. Overall Length, Tailgate Open (in.)	279	301	334	357
D. Overall Height Above Frame, Tailgate Open (in.)	184	184	184	184

Performance Specs	2R-III Heavy Duty Residential	2R-III Heavy Duty Demolition	2R-III Heavy Duty Commercial
Packer/Carrier Cycle Time	23-26 sec	23-26 sec	23-26 sec
Tailgate Open	10 sec @ 700 rpm	10 sec @ 700 rpm	10 sec @ 700 rpm
Tailgate Close (with Safety Flow limiter)	30 sec @ 700 rpm	30 sec @ 700 rpm	30 sec @ 700 rpm



DRIVE EXCELLENCE

